

FPZ-600

Flat Panel Display Stand

For up to 70" Displays

FPZ-600 Flat Panel Display stands provide a safe and secure solution for displaying digital content in public areas like conference rooms, lobbies or convention centers. The versatility and functionality of this solidly engineered stand enables single display, two displays back-to-back, two displays in portrait orientation or even four displays in either landscape or portrait orientations (may require additional accessory). Integrated security fasteners lock the displays in place, virtually eliminating theft, while internal cable management completely hides all wires and cables enabling a clean, professional look.



FEATURES

- Fits single or back-to-back mounted displays up to 70" (up to four with additional dual-display cartridge)
- VESA® 100, 200 x 100, 200 x 200mm compatible. Additional display mounting patterns supported by optional PLP display adaptor plate (sold separately)
- Continuous vertical adjustment on 6' (1.83m) columns for perfect viewing height
- Hook-on design for quick and simple installation
- Easy to switch from portrait to landscape orientation
- Integrated cable management protects, contains and conceals cables for a clean, professional installation
- Includes theft resistant hardware for attaching display to mount



Display size: up to 70"



Max load: 200lb (90.7kg)
per display up to 4 displays

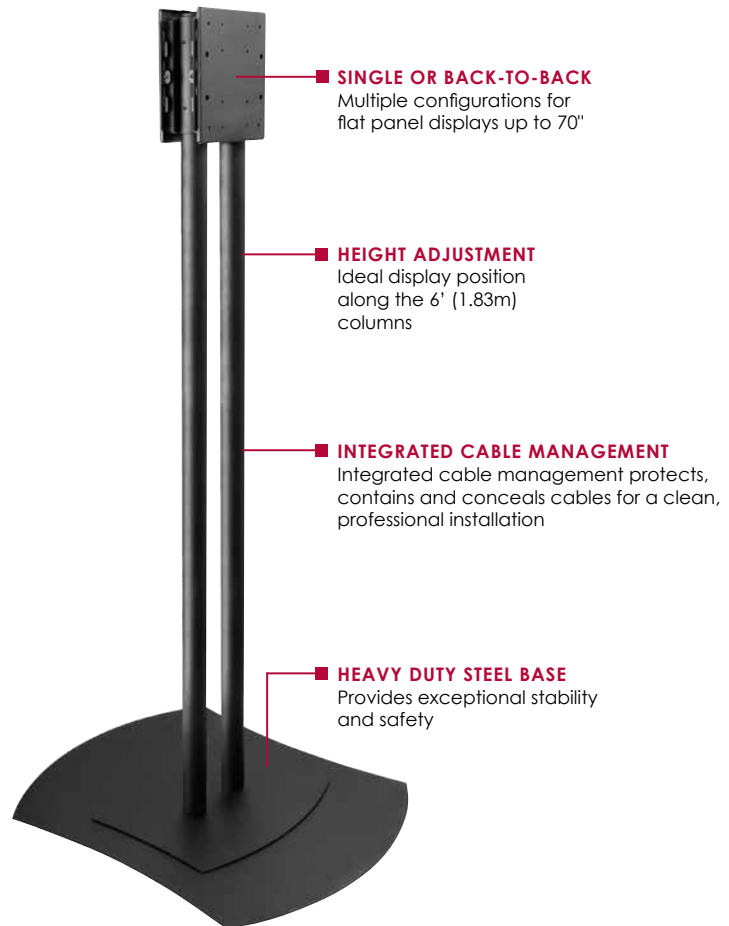

■ **SINGLE OR BACK-TO-BACK**
Multiple configurations for flat panel displays up to 70"

■ **HEIGHT ADJUSTMENT**
Ideal display position along the 6' (1.83m) columns

■ **INTEGRATED CABLE MANAGEMENT**
Integrated cable management protects, contains and conceals cables for a clean, professional installation

■ **HEAVY DUTY STEEL BASE**
Provides exceptional stability and safety



Back-to-back
Landscape



Single display
Portrait



Dual Display
Portrait
(requires ACC604 adaptor)



RoHS
MADE IN USA

CLICK: peerless-av.com

CALL: 800.865.2112

FAX: 800.359.6500

peerless-AV®

FPZ-600 Flat Panel Display Stand for up to 70" Displays

Product Specifications

	DIMENSIONS (W x H x D)	PRODUCT WEIGHT	LOAD CAPACITY	FINISH	AVAILABLE COLORS
FPZ-600	28.91" x 72.33" x 36.00" (734 x 1837 x 914mm)	108.2lb (49kg)	200lb (90.7kg) per display up to 4 displays	Powder Coat	Black

Package Specifications

	PACKAGE SIZE (W x H x D)	PACKAGE SHIP WEIGHT	PACKAGE UPC CODE	PACKAGE CONTENTS	UNITS IN PACKAGE
FPZ-600	Box 1: 37.25" x 30.50" x 9.38" (946 x 775 x 238mm) Box 2 and 3: 72.00" x 4.00" x 8.00" (1830 x 102 x 203mm)	Box 1: 82.9lb (37.6kg) Box 2 and 3: 17.6lb (7.9kg)	735029242604	Floor base, 2 columns, dual-display cartridge, 2 VESA® display adaptor brackets & mounting hardware	1

Accessories

PLP-UNL: Universal Adaptor Plate
ACC604: Dual-Display Cartridge

ACC325: Accessory Shelf
ACC340: Media Player Shelf

All dimensions = inch (mm)

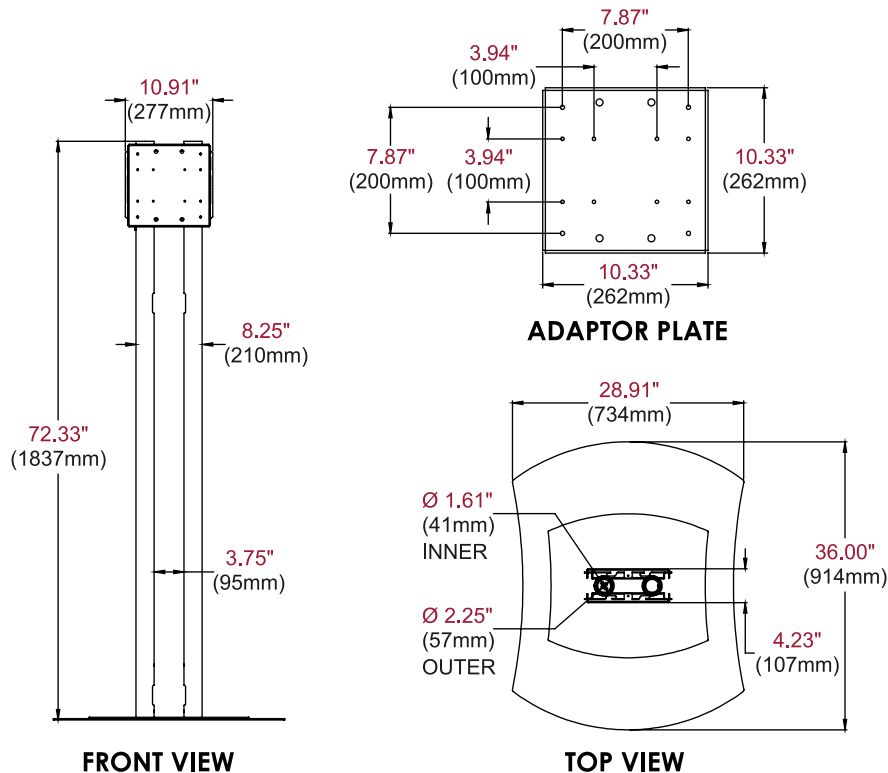

ARCHITECTS SPECIFICATIONS

The Flat Panel Display Stand shall be a Peerless-AV model FPZ-600 and shall be installed where indicated on the plans. It shall be constructed of heavy gauge cold rolled steel. Assembly and installation shall be done according to instructions provided by the manufacturer.

Peerless Industries, Inc. ■ 2300 White Oak Circle ■ Aurora, IL 60502 ■ (800) 865-2112 ■ (630) 375-5100 ■ Fax: (800) 359-6500 ■ peerless-av.com

Visit www.peerless-av.com to see the complete line of AV solutions from Peerless-AV, including flat panel mounts, projector mounts, carts/stands, furniture, cables, screen cleaners and a full assortment of accessories.